

RULES OF CURLING FOR GENERAL PLAY
Page 2

RULES OF CURLING FOR OFFICIATED PLAY
Page 22

**Copies of this handbook may be obtained from your provincial/territorial curling association, your curling club, or from the Canadian Curling Association, 1660 Vimont Court, Cumberland, ON K4A 4J4
E-mail: cca@curling.ca
Website: www.curling.ca**

PUBLISHED - SEPTEMBER, 2005
EXPIRES - SEPTEMBER, 2007



Canadian
Heritage

Patrimoine
canadien



RULES OF CURLING FOR GENERAL PLAY

CONTENTS

	<i>Page</i>
Code of Ethics.....	3
Application.....	4
Definitions.....	4
Sheet.....	5
Stones.....	7
Teams.....	8
Skips.....	10
Position of Players.....	10
Delivery.....	11
Touched Delivered Stone or Stone(s) Set in Motion.....	14
Displaced Stationary Stones.....	15
Sweeping/Brushing.....	16
Free Guard Zone	17
Stones in Play and Scoring.....	18
Measuring.....	20
Equipment.....	20
Game Duration and Postponement.....	21
Miscellaneous.....	21

To ensure that all curlers are aware of their responsibilities when playing the game, the Canadian Curling Association has adopted the following Code of Ethics as an official supplement to the Rules of Curling:

Curlers' Code of Ethics

*I will play the game with a spirit of good sportsmanship.
I will conduct myself in an honourable manner both on and off the ice.
I will never knowingly break a rule, but if I do, I will divulge the breach.
I will take no action that could be interpreted as an attempt to intimidate or demean my opponents, teammates or officials.
I will interpret the rules in an impartial manner, always keeping in mind that the purpose of the rules is to ensure that the game is played in an orderly and fair manner.
I will humbly accept any penalty that the governing body at any level of curling deems appropriate, if I am found in violation of the Code of Ethics or rules of the game.*

Coaching Code of Ethics

*The coach shall act with integrity in performing all duties owed to athletes, the sport, other members of the coaching profession and the public.
The coach shall strive to be well prepared and current in order that all duties in his/her discipline are fulfilled with competence.
The coach shall act in the best interest of the athlete's development as a whole person.
The coach shall accept both the letter and the spirit of the rules that define and govern the sport.
The coach shall accept the role of officials in providing judgment to ensure that competitions are conducted fairly and in accordance with the established rules.
The coach's conduct toward other coaches shall be characterized by courtesy, good faith and respect.
The coach shall maintain the highest standards of personal conduct and support the principles of Fair Play.*

Fair Play

*Fair Play begins with the strict observance of the written rule; however, in most cases, Fair Play involves something more than even unflinching observance of the written rule. The observance of the spirit of the rules, whether written or unwritten, is important. Fair Play results from measuring up to one's own moral standards while engaged in competition.
Fair Play is consistent demonstration of respect for teammates and opponents, whether they are winning or losing.
Fair Play is consistent demonstration of respect for officials, an acceptance of their decisions and a steadfast spirit of collaboration with them.
Sportsmanlike behaviour should be demonstrated both on and off the ice. This includes modesty in victory and composure in defeat.*

RULES OF CURLING FOR GENERAL PLAY

1. Application

- (1) The Rules of Curling for General Play apply to any competition to which they are made applicable by the curling body having jurisdiction.
- (2) The Rules of Curling for General Play are not intended to be used in conjunction with officiating. If a curling body having jurisdiction over an event(s) wishes to make this rule book applicable to a specific competition(s) while also utilizing officials, they should also put in place a set of guidelines outlining the authority of the officials relative to the implementation of penalties.
- (3) If special rules are in effect, they shall take precedence over the General Rules of Curling.

2. Definitions

- (1) “biting” means that the vertical projection of a stone is in contact with the sheet line(s) to which the stone is in close proximity.
- (2) “CCA” means the Canadian Curling Association.
- (3) “competition” means a playdown involving any number of teams playing games to determine a winner.
- (4) “counting stone” means any stationary stone in the house that is closer to the tee than any stationary stone of the opposing team.
- (5) “delivering team” means the team who is in control of the house and whose turn it is to deliver.
- (6) “end” means the part of the game in which two opposing teams each deliver eight stones alternately and then determine the score.
- (7) “game” means play between two teams to determine a winner.
- (8) “house” means the area within the outside circle at each end of the sheet.
- (9) “sheet” means an area of ice marked in accordance with Rule 3.
- (10) “delivered stone” means a stone that is in motion from the moment that it has reached the nearer tee line and been released, until it has come to rest or is out of play.
- (11) “stone set in motion” means a stone in motion whose movement from a stationary position, in play, is caused by a delivered stone or another stone previously set in motion.

- (12) “team” means three or four players playing together in accordance with Rule 5 and may also include the team alternate and coach as determined by the rules of the competition.
- (13) “original position” means the position the stones were in immediately before the violation or incident took place.

3. Sheet

- (1) The recommended length of the sheet from backboard to backboard shall be 146 feet (44.501 meters). The width of the sheet from sideline to sideline shall be a minimum of 14 feet 2 inches (4.318 meters) and a maximum of 15 feet 7 inches (4.75 meters). This area shall be delineated by lines drawn or dividers placed on the perimeter.
- (2) The centre line, one-half inch in width, shall be placed the length of the sheet through the centre of the tee lines to a point 12 feet (3.658 meters) behind each tee. At this point, a line one-half inch in width (1.27 centimetres) and 1 foot 6 inches (45.72 centimetres) in length shall be placed at right angles to the centre line and shall be known as the hack line. The inside (circle side) edge of the hack boards shall be placed on this hack line.
- (3) At each end of the sheet there shall be three distinct lines drawn from sideline to sideline as follows:
 - (a) each tee line, one-half inch in width, shall be placed 12 feet (3.658 meters) from the hack line to the centre of the tee line and there shall be 114 feet (34.747 meters) from the centre of one tee line to the centre of the other tee line. The distance from the backboard to the centre of the tee line shall be 16 feet (4.877 meters) if the length of the sheet is 146 feet (44.501 meters) from backboard to backboard. The intersection of the tee line and the centre line is called the tee.
 - (b) each back line, one-half inch in width, shall be placed with its outer edge 6 feet (1.829 meters) from the centre of the tee line, so that the outer edge of the back line (hack side) is a tangent with the 12 foot circle touching the outer edge of the outer circle exactly 6 feet (1.829 meters) from the tee, where the back line intersects the centre line.
 - (c) the hogline, 4 inches (10.16 centimetres) in width, shall be placed with the inner (circle side) edge 21 feet (6.401 meters) from the centre of the tee line.

Rules of Curling for General Play

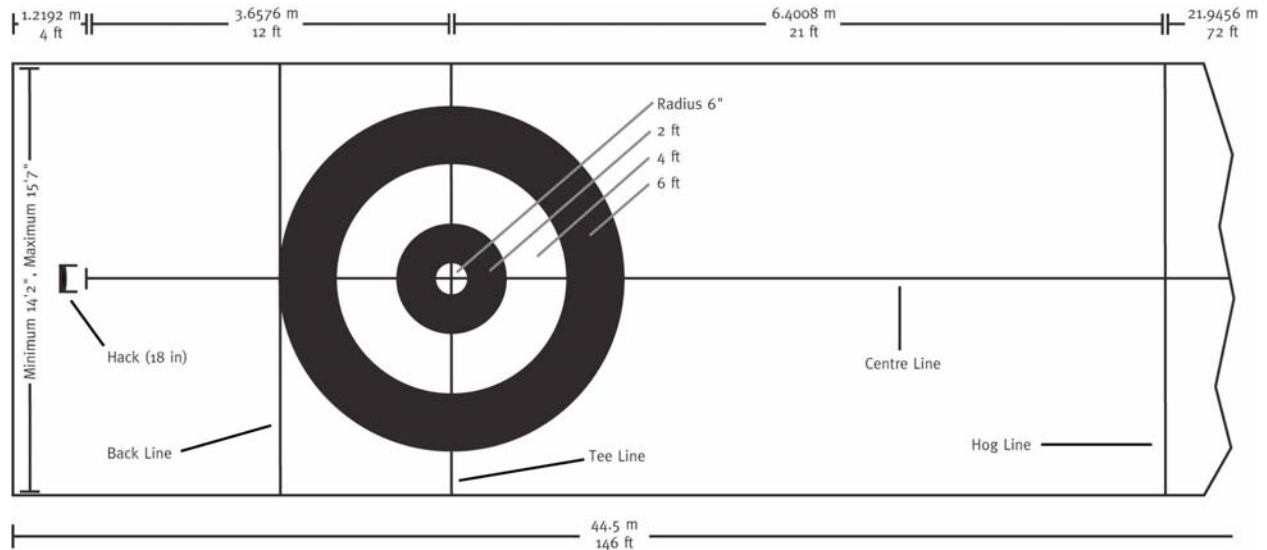

- (4) With each tee as centre, there shall be drawn four concentric circles at each end with the outer edge of the outer circle having a radius of 6 feet (1.829 meters), the next circle 4 feet (1.219 meters), the next circle 2 feet (60.96 centimetres) and the inner circle a minimum of 6 inches (15.24 centimetres). The marking of the centre line and tee line may be omitted from the inner circle
- (5) The intersection of each tee line and each centre line shall be identified by an adjustable tee centre. The base portion shall be securely anchored at the exact intersection of the tee line and centre line of each house, and the top portion should be capable of vertical adjustment to suit varying ice levels. The design of the tee centre shall be accepted by the CCA.
- (6) The hack(s) used for delivery shall be of a style and size accepted by the CCA. The hack(s) shall not exceed 8 inches (20.32 centimetres) in length.
 - (a) If two hacks are used, the back edge of each hack shall be placed on the hack lines and that the inside edge of each hack shall be no further than 3 inches (7.62 centimetres) from the centre line.
 - (b) If one moveable hack is used, it shall be placed with the back edge of the hack on the hack line and be either centered on the centre line or with the inside edge no further than 3 inches (7.62 centimetres) from the centre line (left or right).
 - (c) If one fixed hack is used, it shall be placed with the back edge of the hack on the hack line and centered on the centre line.
- (7) The diagram herein shows the proper layout of the sheet in accordance with the measurements in this section.

Rules of Curling for General Play

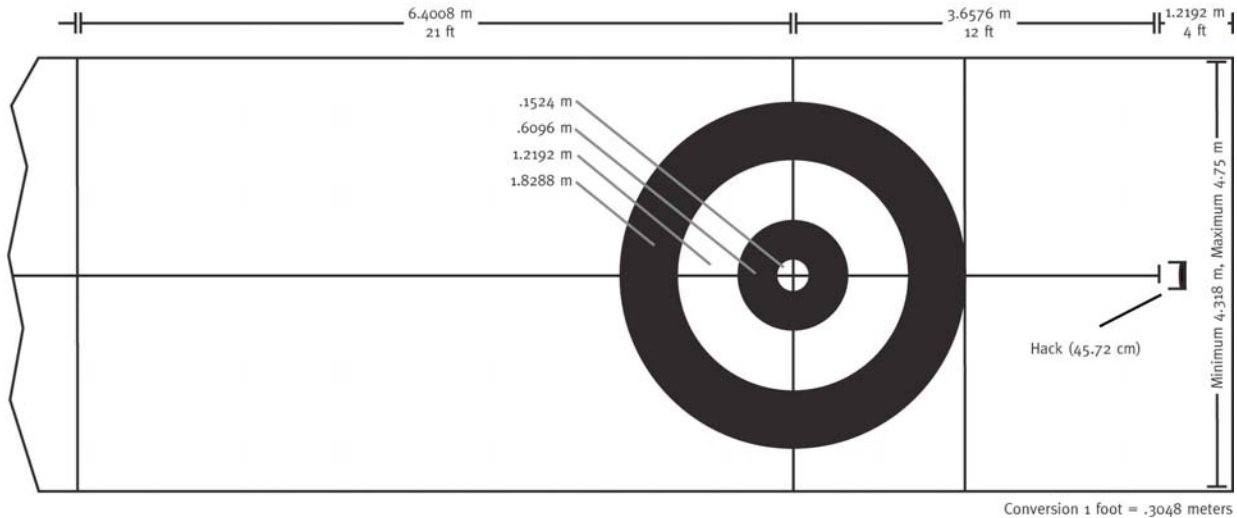

4. Stones

- (1) Curling stones shall be of circular shape.
- (2) Curling stones, including handle and bolt, shall weigh a maximum of 44 lbs. (19.96 kilograms), shall have a maximum circumference of 36 inches (91.44 centimetres) and shall be a maximum of 4.5 inches (11.43 centimetres) in height, measured between the bottom and top of the stone.
- (3) Two sets of eight stones shall be provided for each sheet of play.
- (4) A team member or coach shall not physically alter the running surface or weight of either teams' assigned or selected game stones in any manner.
- (5) If a stone is broken in play, a replacement stone shall be placed where the largest fragment comes to rest. The inside edge of the replacement stone shall be placed in the same position as the inside edge of the largest fragment with the assistance of a measuring stick.
- (6) A stone that rolls over in its course or comes to rest on its side or top shall be removed immediately from play.
- (7) All 16 stones originally on the sheet at the start of a game shall be delivered in every completed end. No interchange of stones or redelivery of previously delivered stones in that end may take place so that a stone is delivered for the second time.

Penalty: If a team declares its own violation of Rule 4(7), the non-offending team may allow the play to stand or remove the stone just delivered from play and replace all affected stones as close as possible to their original positions.

5. Teams

- (1) Every team shall be composed of a minimum of four players as determined by the rules of the competition except as provided for in Rule 5(5). Prior to each game, the team shall designate the four eligible members of the team who will commence play as players for that team.
- (2) Unless otherwise specified in the rules of the competition:
 - (a) the teams opposing each other in a game shall toss a coin to determine which team plays the first stone in the first end. The winner of the toss has the choice between playing the first or second stone of the end; and
 - (b) the team that plays the first stone of the end has choice of handle colour.

In the second and subsequent ends, the winner of the preceding end shall play the first stone of the end.

- (3) Each player on a four player team shall deliver two stones in each end alternately with his/her opponent.
- (4) The delivery rotation declared by a team prior to the start of a game shall be followed throughout that game except as provided for in Rule 5(5), 5(6) or 5(7).
- (5) Unless otherwise specified in the rules of the competition:
 - (a) A team shall include a minimum of two players from the original team and a substitute player(s). A team that is missing a player(s) may use a substitute player(s).
 - (b) A substitute player shall be a team's designated alternate, a player from a players' pool or other eligible player as provided for in the rules of the competition.
 - (c) A team may play with three players with the first two players each delivering three stones in each end. Under no circumstance may a team play with fewer than three players delivering stones.
 - (d) A substitute player who joins a team prior to the start of a game may deliver stones in any position of the delivery rotation of the team. The team shall declare their delivery rotation at this time.
 - (e) A substitute player who joins a team between ends may deliver stones in any position of the delivery rotation of his/her team. Players may move up or down the delivery rotation only as required to position the substitute player and the team shall re-declare their delivery rotation at this time.
 - (f) During an end in play, if a player(s) is unable to complete the delivery rotation declared by the team at the start of the game the team may activate a substitute player(s) subject to:

- i) a substitute player may only enter a game during an end if they deliver a stone within that end; and
 - ii) a substitute player(s) who enters a game during an end shall replace the sidelined player(s) in the team's delivery rotation for that end; and
 - iii) at the beginning of the next end the substitute player may deliver stones in any position of the delivery rotation of his/her team. Players may move up or down in the delivery rotation only as required to position the substitute player and the team shall re-declare their delivery rotation at this time; and
 - iv) the replaced team member shall not rejoin the team until the next game unless the team loses a subsequent player(s) and is therefore placed in a default position as per Rule 5(5)(a) and (b).
- (6)
 - (a) A team that commences a game with three players and expects the fourth player to join the team during the game shall establish the team's four player delivery rotation prior to commencing the game.
 - (b) A player who is late for a game may enter the game between ends or may enter an end already in progress providing he/she is able to deliver a stone within the team's established delivery rotation.
 - (c) A player who has left a game may re-enter the game between ends or during an end already in progress providing he/she is able to deliver a stone within the team's established delivery rotation. If a substitute player has been activated, the replaced team member shall not rejoin the team until the next game except as provided in Rule 5(5)(f) iv).
- (7)
 - (a) If a player delivers his/her first stone of the end and is unable to deliver his/her second stone of the end and the rules of the competition allow the team to continue play with three players and the team chooses to play with three players, the following procedures shall be followed:
 - If the lead player, the second player shall deliver the lead player's stone.
 - If the second player, the lead player shall deliver the second player's stone.
 - If the third player, the second player shall deliver the third player's stone.
 - If the fourth player, the third player shall deliver the fourth player's stone.
 - (b) If a player is unable to deliver both his/her stones during an end and the rules of the competition allow the team to continue with three players and the team chooses to play with three players, the following procedures shall be followed for the end in progress:
 - If the lead player, the second player shall deliver both of the lead player's stones and one of the second player's stones, and the third

player shall deliver one of the second player's stones and both of the third player's stones.

- If the second player, the lead player shall deliver the first of the second player's stones, and the third player shall deliver the second of the second player's stones and both of the third player's stones.
- If the third player, the second player shall deliver both of the third player's stones.
- If the fourth player, the third player shall deliver both of the fourth player's stones.

Penalty: If a team declares its own violation of Rule 5(4), 5(5), 5(6), or 5(7), all stones shall be allowed to come to rest before any action is taken. At this time, the non-offending team may allow the play to stand or remove the stone just delivered from play and replace all affected stones as close as possible to their original positions.

6. Skips

- (1) The skip has the exclusive direction of the game for his/her team and shall deliver stones in each end except as provided for in Rule 5(7).
- (2) Subject to Rule 5(4), the skip may play any position in the delivery rotation of his/her team. Regardless of the position played in the delivery rotation, the player designated as skip shall remain in that capacity throughout the course of that game except as provided for in Rule 5(6).
- (3) When it is the skip's turn to deliver, he/she shall elect a teammate to act as skip. Subject to Rule 5(4), the vice-skip may play any position in the delivery rotation of his/her team. Regardless of the position played in the delivery rotation, the player designated as vice-skip shall remain in that capacity throughout the course of that game except as provided for in Rule 5(6). The vice-skip shall assume the responsibilities of the skip when the skip is not on the playing surface.

Penalty: If a team declares its own violation of Rule 6(1), 6(2) or 6(3), all stones shall be allowed to come to rest before any action is taken. At this time, the non-offending team may allow the play to stand or remove the stone just delivered from play and replace all affected stones as close as possible to their original positions.

7. Position of Players

- (1) Members of the non-delivering team:
 - (a) The skip and vice-skip and only the skip and vice-skip may be positioned inside the hogline at the playing end and shall position themselves behind the back line when the delivering team is in the process of delivery. Both

players shall be motionless with their brooms positioned in a manner not to interfere with or distract the attention of the player who is in the process of delivery as provided for in Rule 8(2).

- (b) One player may take a stationary position by the backboard at the delivering end and to the side of the sheet. The player shall remain silent and motionless when the delivering team player is in the process of delivery as provided for in Rule 8(2).
- (c) The players not taking the positions 7(1)(a) or 7(1)(b) shall position themselves between the hoglines and to the extreme sides of the sheet when the opposing team is delivering a stone. The players positioned in this area shall remain in single file when the delivering team player is in the process of delivery as provided for in Rule 8(2).
- (d) The non-delivering team members shall not take any position or cause such motion that would obstruct, interfere with or distract any member of the delivering team.

Penalty: If a team declares its own violation of Rule 7(1)(a), 7(1)(b), 7(1)(c) or 7(1)(d), all stones shall be allowed to come to rest before any action is taken. At this time, the non-offending team has the option of:

- i) allowing the play to stand; or
- ii) recommencing the delivery of the stone; or
- iii) replacing all affected stones as close as possible to their original position and redelivering the stone

(2) Members of the delivering team:

- (a) The skip or vice-skip shall be positioned inside the hogline and on the ice surface of the playing end while their team is in the process of delivery. They shall have choice of position for the purpose of directing play.

Penalty: If a team declares its own violation of Rule 7(2)(a), all stones shall be allowed to come to rest before any action is taken. At this time, the non-offending team may allow the play to stand or remove the stone just delivered from play and replace all affected stones as close as possible to their original positions.

8. Delivery

- (1) Only right-handed deliveries shall be initiated from the hack located to the left of the centre line and only left-handed deliveries shall be initiated from the hack located to the right of the centre line. Both right-handed and left-handed deliveries may be initiated from a hack located on the centre line.

Rules of Curling for General Play

Interpretation: If a single, moveable hack is in use it shall be positioned as required by the delivering team in accordance with Rule 3(6) and 8(1).

Interpretation: The delivery and release of a curling stone are intended to occur within a reasonable proximity to the centre line.

Penalty: If a team declares its own violation of Rule 8(1), all stones shall be allowed to come to rest before any action is taken. At this time, the non-offending team may allow the play to stand or remove the stone just delivered from play and replace all affected stones as close as possible to their original positions.

- (2) (a) A player whose team is in control of the house is deemed to be in the process of delivery from the time the player is positioned in the hack until the stone is released.
- (b) A player shall only commence a forward progression from the hack with a stone after the previously delivered stone and any stones set in motion have come to rest or have crossed the back line and his/her team is in control of the house.

- (3) In the delivery of a stone, the stone shall be released before the stone has reached the nearer hogline.

Penalty: The delivered stone and all affected stones shall be allowed to come to rest before any action is taken. If a team declares its own violation of Rule 8(3), the non-offending team shall remove the stone just delivered from play and replace all affected stones as close as possible to their original positions.

- (4) If a player wishes to recommence the delivery as a result of his/her own team's action, the player may do so providing the stone has not reached the nearer tee line.

Interpretation: The delivery may be recommenced if the player's body or equipment reaches the tee line providing the stone does not.

- (5) If an extreme circumstance occurs during the delivery that distracts the thrower to a significant degree during the process of delivery [Rule 8(2)], the stone may be redelivered prior to the opposition delivering their next stone.
- (6) Each player shall be ready to deliver when his/her turn comes.
- (7) Delay of a game in progress by a player for any reason excluding accident or illness shall not exceed three minutes.
- (8) If a player delivers a stone belonging to the opposing team, a stone belonging to his/her team shall be put in its place.

- (9) (a) If a player delivers a stone out of proper rotation, the end shall continue and the delivery rotation shall continue to be in accordance with Rule 5(3) and 5(4), except as provided for in rule 5(7).

Interpretation: This includes the situation when the team with last stone throws first.

- (b) If an error in delivery rotation causes a player on the same team to miss a turn, the player who has missed a turn shall deliver the last stone for his/her team in the end.

Interpretation: This rule applies to the situation when the second player delivers the lead player's second stone and other similar delivery rotation errors.

- (10) If the opposing teams agree that a stone has been missed but are unable to determine which player missed his/her turn, the lead of the team that missed a turn shall play the last stone for his/her team in that end.

- (11) (a) If a team delivers two stones in succession in the same end, they shall remove the second stone that was played, replace any stone(s) displaced by the stone and the end shall continue. The delivery rotation of the offending team shall be altered for that end so that the player who delivered the second of the two stones delivered in succession shall deliver the last stone for his/her team in that end.

- (b) If the non-offending team delivers a stone prior to the error in delivery rotation being detected, the end shall be continued. If the non-offending team has last stone they shall deliver the last two stones of the end in succession. If the non-offending team is the team who started the end without last stone they shall deliver the last stone of the end.

- (12) If a player on a four player team delivers three stones in one end, except as provided for in Rule 5(7), the end shall be continued and the fourth player on the offending team shall deliver one stone only in that end.

- (13) If the handle came off of a stone during the process of the delivery [Rule 8(2)], the delivering team may:

- (i) allow the play to stand, or
- (ii) redeliver the stone after all affected stones have been replaced as close as possible to their original position.

The delivering team must make their choice prior to the opposition delivering their next stone.

Interpretation: This does not apply to a handle that is loose but did not separate from the stone.

9. Touched Delivered Stone or Stone(s) Set in Motion

- (1) A delivered stone or stone set in motion shall not be touched by any player, equipment or personal belongings of the team to which it belongs.

Interpretation: A stone which has been released (fingers and thumb no longer in contact with the handle) and then retouched by the delivering player is considered a touched delivered stone and thus a breach of Rule 9(1). A player who repositions his/her hand on the handle while in the process of delivery and does so without losing contact with the handle is not in breach of Rule 9(1).

Penalty: If the violation occurs after the stone has been released, all stones shall be allowed to come to rest before any action is taken. If a team declares its own violation of Rule 9(1) the non-offending team may then remove the touched stone from play and replace all affected stones as close as possible to their original positions unless they select either of these alternative options:

- i) allowing the play to stand; or
- ii) placing the touched stone and all stones it would have affected where they would have come to rest had the violation not occurred. This option is only applicable where the violation occurred inside the hogline at the end of play or involved a stone considered to be in play.

- (2) A delivered stone shall not be touched by any player of the opposing team or their equipment nor shall they cause the stone to be touched.

Penalty: All stones shall be allowed to come to rest before any action is taken. If a team declares its own violation of Rule 9(2) the non-offending team has the option of:

- i) allowing the play to stand; or
- ii) replacing all affected stones as close as possible to their original position and redelivering the stone; or
- iii) placing the touched stone and all stones it affected or would have affected where they would have come to rest had the violation not occurred. This option is only applicable where the violation occurred inside the hogline at the end of play or involved a stone considered to be in play.

- (3) A stone set in motion shall not be touched by any player of the opposing team or their equipment nor shall they cause the stone to be touched.

Penalty: All stones shall be allowed to come to rest before any action is taken. If a team declares its own violation of Rule 9(3), the non-offending team has the option of:

- i) allowing the play to stand; or
- ii) placing the touched stone and all stones it affected or would have affected where they would have come to rest had the violation not occurred.

- (4) If a delivered stone or stone in the process of delivery was touched or caused to be touched by an external force, i.e. stone, broom or brush from another sheet, spectator, etc., the player shall redeliver the stone. If the touched stone has displaced other stones, they shall be replaced as close as possible to their original positions to the satisfaction of both teams.
- (5) If a stone(s) set in motion was touched or caused to be touched by an external force, the stone(s) set in motion and all stones they would have affected shall be placed where they would have come to rest had the incident not occurred with placement to the satisfaction of both teams.

10. Displaced Stationary Stones

- (1) A stationary stone shall not be displaced by a player or that player's equipment nor shall a player cause a stone to be displaced by an opposing player or that player's equipment.

Penalty - Situation #1: If a team declares its own violation of Rule 10(1), and the displaced stone did not alter and would not have altered the course of a delivered stone or stone in motion,

- i) the non-offending team shall replace the displaced stone(s) as close as possible to its original position, and
- ii) if the displacement occurred while playing the final stone of the end and/or prior to agreement of the score, Rule 13(9) shall apply.

Interpretation: If there is any question as to which stone(s) was closer to the tee, the displaced stone shall be positioned in favour of the non-offending team.

Penalty - Situation #2: If a team declares its own violation of Rule 10(1) and the displaced stationary stone altered or would have altered the course of a delivered stone or stone set in motion, all stones shall be allowed to come to rest before any action is taken. At this time the non-offending team has the option of:

- i) allowing the play to stand; or
- ii) placing the stone just delivered or stone set in motion and all stones it would have affected where they would have come to rest had the violation not occurred; or
- iii) removing the stone just delivered or stone set in motion from play and replacing all affected stones as close as possible to their original positions.

Interpretation: If there is any question as to which stone(s) would have been closer to the tee had the violation not occurred, the stone(s) that was affected or would have been affected by the delivered stone or stone set in motion shall be positioned in favor of the non-offending team.

- (2) The delivering team shall prevent a stationary stone(s) from being displaced by a stone(s) that is deflected from a divider or from a stationary stone on another sheet.

Penalty: If a team declares its own violation of Rule 10(2), all stones shall be allowed to come to rest before any action is taken. At this time the non-

offending team shall replace the displaced stationary stone(s) as close as possible to its original position. If the displacement occurred while playing the final stone of an end and prior to agreement of the score, Rule 13(9) shall apply.

Interpretation: If there is any question as to which stone(s) was closer to the tee or would have been closer to the tee had the violation not occurred, the displaced stone(s) or stone(s) in motion shall be positioned in favor of the non-offending team.

- (3) If the stones are displaced during an end in a way other than stated in the preceding rules, the teams shall determine the positions to which the stones are to be returned, subject to:
 - a) If the teams cannot agree on the original position of the displaced stones relative to which was closer to the tee, the end shall be replayed; and
 - b) If the displacement occurred at the conclusion of play in an end and prior to agreement of the score, Rule 13(9) shall apply.

11. Sweeping/Brushing

- (1) Between the tee lines, all members of the delivering team may sweep/brush any of their team's stones that have been delivered or set in motion.
- (2) Only the skip or vice-skip of the non-delivering team may sweep/brush their team's stone(s) after it is set in motion.
- (3) Behind the tee line, only one player from each team may sweep/brush at one time. This may be the skip or vice-skip of either team or the lead or second of the delivering team.

Interpretation: The only time a lead or second of the delivering team may sweep/brush behind the tee line is when sweeping/brushing his/her team's delivered stone or any stone set in motion.

- (4) Behind the tee line, the delivering team shall have first privilege of sweeping/brushing any stone. If their choice is not to sweep/brush, they shall not obstruct or prevent the non-delivering skip or vice skip from sweeping/brushing the stone.
- (5) An opponent's delivered stone or stone set in motion shall not be swept/brushed until it reaches the farther tee line and sweeping/brushing shall only take place behind the tee line.

Penalty: If a team declares its own violation of Rule 11(1), 11(2), 11(3), 11(4) or 11(5), all stones shall be allowed to come to rest before any action is taken. At this time the non-offending team may allow the play to stand or place the stone and all stones it would have affected where they would have come to rest had the sweeping violation not occurred.

- (6) (a) The sweeping/brushing motion shall be from side to side.

- (b) The sweeping/brushing motion shall not leave any debris in front of a delivered stone or stone set in motion.
 - (c) The final sweeping/brushing motion shall finish to either side of the delivered stone or stone set in motion.
- (7) All sweeping/brushing shall take place in front of the delivered stone or stone set in motion and within 6 feet (1.83 meters) of the stone.
- (8) When sweeping with a corn/straw broom, the sweeping motion shall take place with the corn/straw pointing in the direction of play.

Interpretation: Backward sweeping with a corn/straw broom is not acceptable.

Penalty: If a team declares its own violation of Rule 11(6), 11(7) or 11(8), all stones shall be allowed to come to rest before any action is taken. At this time the non-offending team has the option of:

- i) allowing the play to stand; or
- ii) removing the unfairly swept/brushed stone from play and replacing all affected stones as close as possible to their original position; or
- iii) placing the unfairly swept/brushed stone and stone(s) it would have affected where they would have come to rest had the sweeping/brushing violation not occurred.

12. Free Guard Zone

- (1) The free guard zone is the area between the hogline and the tee line, excluding the house.

Interpretation: A stone which comes to rest biting or in front of the hogline after making contact with a stone in the free guard zone is considered to be in the free guard zone. A stone which comes to rest outside the house but biting the tee line is not considered to be in the free guard zone.

- (2) Any stationary stone(s) belonging to the opposition that is located in the free guard zone shall not be moved to an out-of-play position by the delivering team prior to the delivery of the 5th stone of the end.

Penalty: A stone that is delivered prior to the 5th stone of the end that results in an opposition stone being moved from the free guard zone, either directly or indirectly, to an out-of-play position is an infraction which shall result in the delivered stone being removed from play and any other stone if moved being replaced as close as possible to its original position.

Interpretation: A delivered third or fourth stone of an end may hit an opposition stone(s) located in the free guard zone on to a stone(s) not in the free guard zone providing that any opposition stone originally located in the free guard zone remains in play. If this action results in an opposition free guard zone stone being moved to an out-of-play position, the penalty described above will apply. You may

move your own stone from the free guard zone or remove your own stone from the free guard zone, providing you do not cause an opposition stone to be moved from the free guard zone to an out-of-play position.

- (3) After the delivery of each of the first three stones of an end it is the responsibility of the skip of the team who is about to deliver to ensure agreement with the opposing skip as to whether or not any of the stone(s) in play have come to rest in the free guard zone. If they cannot agree, they may make the determination by using the six foot measuring stick. If the position of another stone(s) hinders the use of the six foot measure they may reposition the stone(s), complete the measurement and replace the stone(s) to its original position.

13. Stones in Play and Scoring

- (1) A stone that does not come to rest inside the inner edge (house side) of the farther hogline shall be removed from play immediately except where it has struck another stone lying in play.

Interpretation: A stone which crosses the hogline but, when stopping, spins such that it comes to rest biting the hogline, is considered "out of play".

- (2) A stone coming to rest beyond the outer edge of the back line shall be immediately removed from play.

Interpretation: A stone which crosses the back line but, when stopping, spins such that it comes to rest biting the back line, is considered "in play".

- (3) A stone that touches a sideline, hits a divider or comes to rest biting a sideline shall be removed immediately from play.

Interpretation: If a delivered stone or stone in motion hits a stationary stone and a sideline or divider at the same time, the stationary stone shall be allowed to take its course as if it had been hit first.

- (4) A game shall be decided by a majority of points.
- (5) Each stone, any part of which is within 6 feet (1.83 meters) of the tee, is eligible to be counted.
- (6) A team scores one point for each eligible stone that is closer to the tee than any stone of the opposing team.
- (7) An end shall be decided when the skips or vice-skips in charge of the house at the time agree upon the score for the end.
- (8) If two or more stones are tied, then none of the tied stones shall count and only stones closer to the tee than the tied stones shall be eligible to be counted. If the tied stones are to determine which team shall count in that end, the end shall be considered blank.

- (9) If a stone(s) which may have affected the points scored in an end is displaced prior to the skips or vice-skips deciding the score, the team causing the displacement shall forfeit the point(s) involved.
- (10) Should an individual other than the two teams or their coaches displace or cause the displacement of a stone(s) prior to agreement of the score or a measure being determined, the following shall apply:
- (a) Preceding the final end;
- (i) If the displaced stone(s) would have determined who won an end, the end shall be replayed.
- (ii) If a team secured a point(s) and the displaced stone(s) would have determined if an additional point(s) was scored, that team shall have the option of replaying the end or keeping the point(s) already secured and proceeding to the next end.
- (b) In the final end:
- (i) If the game is tied and the displaced stone(s) would have determined which team won the game, the end shall be replayed.
- (ii) If the displaced stone(s) would have determined if the game was tied or lost by the team that was behind in points, that team shall have the option of replaying the end or keeping the point(s) they had already secured and playing an additional end without last rock.
- (iii) If the team that was behind in points had already secured sufficient points to tie the game, and the displaced stone(s) would have determined if they won the game, that team shall have the option of replaying the end or keeping the point(s) already secured and playing an additional end, with last rock being determined by a single draw to the tee with sweeping/brushing. The team who was ahead in points when the end began shall have the choice of drawing first or last.
- (iv) If the displaced stone(s) would have determined if the game was lost, tied or won, the team that was down in points shall have the option of replaying the end or keeping the point(s) already secured, if any, and playing an additional end, with last rock being determined by a single draw to the tee with sweeping/brushing. The team who was ahead in points when the end began shall have the choice of drawing first or last.

Interpretation: Rule 13(10)(b)(iv) applies to the following types of situations:

- A team is one down going home and measuring two of their stones to determine if they have lost, tied or won the game.
- A team is two down going home counting one and measuring two of their stones to determine if they have lost, tied or won the game.

- (11) If after regulation play [Rule 16(1)], the score is tied, play shall be continued without changing the rotation of play (end the stones are thrown to) for such additional end or ends as may be required to decide the winning team.

14. Measuring

- (1) Measurements shall be taken from the tee to the closest part of the stone.

Interpretation: Because stones may vary in diameter, measurements shall not be taken from the tee to the farthest part of a stone.

- (2) No physical device to aid visual observation shall be used in measuring prior to the last stone delivered in the end coming to rest except as provided for in Rule 12(2) and 14(4).

- (3) Decisions on whether a stone is in or out of play at the hogline, sidelines and back line shall be visual (no accepted measuring device) except as provided for in Rule 14(4). If the opposing skips cannot agree, they may request a non-partisan third party to render a decision.

- (4) A skip may conduct a measurement when a stone is located on the back line in proximity to the centre line (6:00 position) to confirm if the stone is in or out of play. The 6 foot (1.83 metres) measuring stick shall be used.

Interpretation: If the position of a stone(s) in the house makes it impossible to use the measuring stick to determine if a stone is in or out of play and the opposing skips cannot agree, they may request a non-partisan third party to render a decision.

- (5) If two or more stones are so close to the tee that a measuring device cannot be used, and if a visual comparison cannot determine which stone is closest to the tee, the stones shall be considered tied. If these stones were to determine who counted in the end, the end shall be considered blank.

- (6) A measuring stick that measures a distance of six feet (1.83 metres) from the tee shall be used, if necessary, to confirm whether a stone is within six feet (1.83 metres) of the tee as provided for in Rule 12(2), 13(5) and 14(4).

15. Equipment

- (1) A player shall not use footwear or equipment that may damage or affect the playing quality of the ice surface. (Examples: excessive debris from a corn/straw broom, shedding brushes, faulty slider or gripper.)

- (2) At the start of each game, each player shall declare what type of sweeping/brushing device that he/she shall be using for the duration of the game (brush, synthetic straw style broom or corn/straw broom). Players may change or exchange brushes, brush heads and synthetic straw style brooms during a game. Players shall use the same corn/straw broom for the duration of the game and shall not exchange a corn/straw broom with another player.

- (3) A broom or brush broken during the game shall be replaced by the same type of sweeping/brushing device.
- (4) The use of a curling aid commonly referred to as a “delivery stick” which enables the player to deliver a stone without placing a hand on the handle is considered acceptable. If a player starts a game with a delivery stick then that player shall use a delivery stick throughout that game. If a player starts a game without a delivery stick, then a delivery stick shall not be used by that player in that game.
- (5) The use of a curling aid commonly referred to as a “delivery balance device” is considered acceptable. The balance device shall not exceed 5 feet (152.4 centimetres) in length and 12 inches (30.5 centimetres) in width. Height may vary.

16. Game Duration and Postponement

- (1) A game shall be of such length or duration as is stated in the rules governing the competition.
- (2) If for any reason a game is postponed to another time, the game shall continue from the last completed end.
- (3) If a team does not commence play at the designated time, unless otherwise stated by the rules governing the competition:
 - i) For each full five minutes that the offending team does not commence play, the non-offending team shall be granted one point and one end shall be considered to have been played; and
 - ii) If the non-offending team has been granted a point(s), the non-offending team shall be given the choice of last rock in the first end or color of handle. Play shall commence from the end of play that reflects the number of ends that are considered to have been played; and
 - iii) After 30 minutes has elapsed the non-offending team shall be declared the winner.

17. Miscellaneous

- (1) If any exceptions to the preceding rules are necessary to accommodate players with physical disabilities, appropriate adjustments are considered acceptable.
- (2) Should any situation occur that is not covered by the rules, the decision shall be made in accordance with equity

RULES OF CURLING FOR OFFICIATED PLAY

CONTENTS

	<i>Page</i>
Code of Ethics	23
Application	25
Definitions	25
Sheet	26
Stones	28
Teams	30
Skips.....	32
Position of Players.....	33
Game Time Operation	34
Delivery	36
Touched Delivered Stone or Stone(s) Set in Motion.....	39
Displaced Stationary Stones.....	40
Sweeping/Brushing.....	42
Free Guard Zone	43
Stones in Play and Scoring.....	44
Measuring.....	45
Equipment	46
Game Duration & Postponement.....	48
Head Official	48
Miscellaneous	49

To ensure that all curlers are aware of their responsibilities when playing the game, the Canadian Curling Association has adopted the following Code of Ethics as an official supplement to the Rules of Curling:

Curlers' Code of Ethics

*I will play the game with a spirit of good sportsmanship.
I will conduct myself in an honourable manner both on and off the ice.
I will never knowingly break a rule, but if I do, I will divulge the breach.
I will take no action that could be interpreted as an attempt to intimidate or demean my opponents, teammates or officials.
I will interpret the rules in an impartial manner, always keeping in mind that the purpose of the rules is to ensure that the game is played in an orderly and fair manner.
I will humbly accept any penalty that the governing body at any level of curling deems appropriate, if I am found in violation of the Code of Ethics or rules of the game.*

Coaching Code of Ethics

*The coach shall act with integrity in performing all duties owed to athletes, the sport, other members of the coaching profession and the public.
The coach shall strive to be well prepared and current in order that all duties in his/her discipline are fulfilled with competence.
The coach shall act in the best interest of the athlete's development as a whole person.
The coach shall accept both the letter and the spirit of the rules that define and govern the sport.
The coach shall accept the role of officials in providing judgment to ensure that competitions are conducted fairly and in accordance with the established rules.
The coach's conduct toward other coaches shall be characterized by courtesy, good faith and respect.
The coach shall maintain the highest standards of personal conduct and support the principles of Fair Play.*

Fair Play

Fair Play begins with the strict observance of the written rule; however, in most cases, Fair Play involves something more than even unfailing observance of the written rule. The observance of the spirit of the rules, whether written or unwritten, is important. Fair Play results from measuring up to one's own moral standards while engaged in competition.

Fair Play is consistent demonstration of respect for teammates and opponents, whether they are winning or losing.

Fair Play is consistent demonstration of respect for officials, an acceptance of their decisions and a steadfast spirit of collaboration with them.

Sportsmanlike behaviour should be demonstrated both on and off the ice. This includes modesty in victory and composure in defeat.

Fair Play Code for Officials

The official shall strive to ensure that every athlete has the opportunity to perform to the best of his or her ability.

The official shall strive to maintain a positive atmosphere and safe environment for competition.

The official shall not permit the intimidation of any athlete either by word or by action.

The official shall not tolerate unacceptable conduct toward himself/herself, other officials, athletes or spectators.

The official shall handle all conflicts firmly and with dignity.

The official shall accept his/her role as a teacher and role model for Fair Play.

The official shall be open to discussion and contact with the athletes as required.

The official shall remain open to constructive criticism and show respect and consideration for different points of view.

The official shall continue to obtain proper training and upgrade his/her officiating skills.

RULES OF CURLING FOR OFFICIATED PLAY

1. Application

- (1) These rules apply to:
 - (a) any competition to which these rules are made applicable by the curling body having jurisdiction; and
 - (b) any competition within the jurisdiction of the CCA including a National Championship where special rules may be in effect.
- (2) If special rules are in effect, they shall take precedence over the Rules of Curling for Officiated Play.
- (3) If a competitors' guide is issued for a specific event, the guide shall form an integral part of the rules for the event and be enforceable as part of the rules.

2. Definitions

In these rules and rulings made by officials, the CCA and its officers:

- (1) "biting" means that the vertical projection of a stone is in contact with the sheet line(s) to which the stone is in close proximity.
- (2) "CCA" means the Canadian Curling Association.
- (3) "competition" means a playdown involving any number of teams playing games to determine a winner.
- (4) "counting stone" means any stationary stone in the house that is closer to the tee than any stationary stone of the opposing team.
- (5) "delivering team" means the team whose time clock is running, is in control of the house and whose turn it is to deliver.
- (6) "end" means the part of the game in which two opposing teams each deliver eight stones alternately and then determine the score.
- (7) "game" means play between two teams to determine a winner.
- (8) "house" means the area within the outside circle at each end of the sheet.
- (9) "National Championship" means:
 - Canadian Men's Curling Championship
 - Canadian Senior Men's Curling Championship

Canadian Junior Men's Curling Championship
Canadian Mixed Curling Championship
Canadian Women's Curling Championship
Canadian Senior Women's Curling Championship
Canadian Junior Women's Curling Championship

- (10) "official" means person or persons assigned to oversee a curling game or competition by the curling body having jurisdiction.
- (11) "officiated play" means play that includes a head official, supervising official(s), hogline officials, game observers, timing officials, time clocks and hogline detection devices as determined by the rules of the competition.
- (12) "sheet" means an area of ice marked in accordance with Rule 3.
- (13) "delivered stone" means a stone that is in motion from the moment that it has reached the nearer tee line and been released, until it has come to rest or is out of play.
- (14) "stone set in motion" means a stone in motion whose movement from a stationary position, in play, is caused by a delivered stone or another stone previously set in motion.
- (15) "team" means three or four players playing together in accordance with Rule 5 and may also include the team alternate and coach as determined by the rules of the competition.
- (16) "time-out" means stopping the delivering team's game time clock and stopping play.
- (17) "original position" means the position the stones were in immediately before a violation or incident took place.
- (18) "violation" means an infraction of a rule as determined by the official.

3. Sheet

- (1) The recommended length of the sheet from backboard to backboard shall be 146 feet (44.501 meters). The width of the sheet from sideline to sideline shall be a minimum of 14 feet 2 inches (4.318 meters) and a maximum of 15 feet 7 inches (4.75 meters). This area shall be delineated by lines drawn or dividers placed on the perimeter.
- (2) The centre line, one-half inch in width, shall be placed the length of the sheet through the centre of the tee lines to a point 12 feet (3.658 meters) behind each tee. At this point, a line one-half inch in width (1.27 centimetres) and 1 foot 6 inches (45.72 centimetres) in length shall be placed at right angles to the centre line and shall be known as the hack line. The inside (circle side) edge of the hack boards shall be placed on this hack line.

- (3) At each end of the sheet there shall be three distinct lines drawn from sideline to sideline as follows:
- (a) each tee line, one-half inch in width, shall be placed 12 feet (3.658 meters) from the hack line to the centre of the tee line and there shall be 114 feet (34.747 meters) from the centre of one tee line to the centre of the other tee line. The distance from the backboard to the centre of the tee line shall be 16 feet (4.877 meters) if the length of the sheet is 146 feet (44.501 meters) from backboard to backboard. The intersection of the tee line and the centre line is called the tee.
 - (b) each back line, one-half inch in width, shall be placed with its outer edge 6 feet (1.829 meters) from the centre of the tee line, so that the outer edge of the back line (hack side) is a tangent with the 12 foot circle touching the outer edge of the outer circle exactly 6 feet (1.829 meters) from the tee, where the back line intersects the centre line.
 - (c) the hogline, 4 inches (10.16 centimetres) in width, shall be placed with the inner (circle side) edge 21 feet (6.401 meters) from the centre of the tee line.

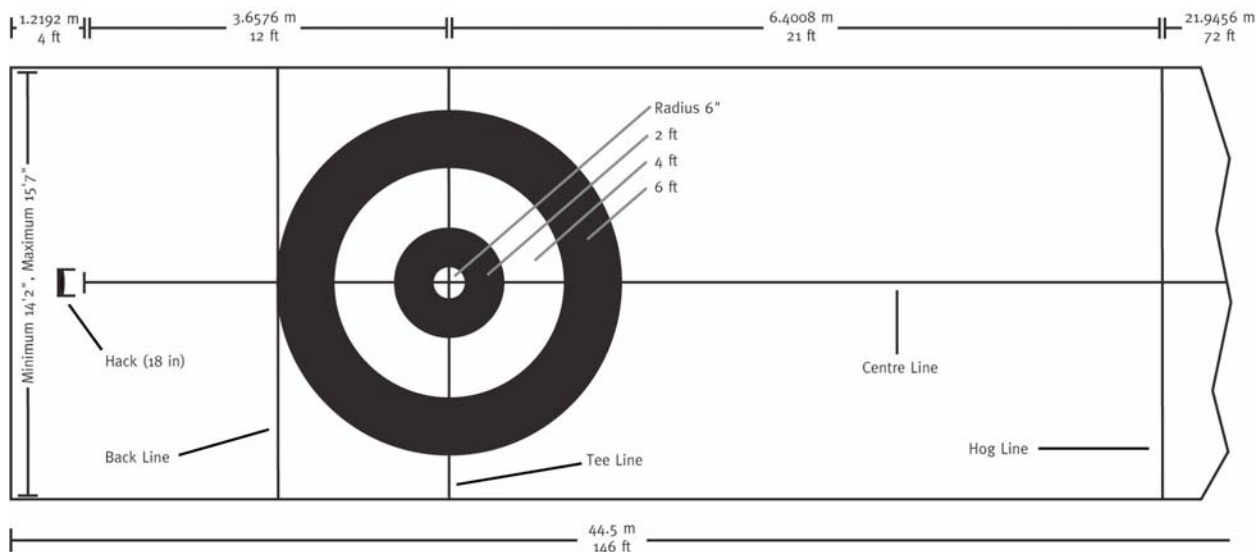

- (4) With each tee as centre, there shall be drawn four concentric circles at each end with the outer edge of the outer circle having a radius of 6 feet (1.829 meters), the next circle 4 feet (1.219 meters), the next circle 2 feet (60.96 centimetres) and the inner circle a minimum of 6 inches (15.24 centimetres). The marking of the centre line and tee line may be omitted from the inner circle
- (5) The intersection of each tee line and each centre line shall be identified by an adjustable tee centre. The base portion shall be securely anchored at the exact intersection of the tee line and centre line of each house, and the top portion should be capable of vertical adjustment to suit varying ice levels. The design of the tee centre shall be accepted by the CCA.

Rules of Curling for Officiated Play

- (6) The hack(s) used for delivery shall be of a style and size accepted by the CCA. The hack(s) shall not exceed 8 inches (20.32 centimetres) in length.
- (a) If two hacks are used, the back edge of each hack shall be placed on the hack lines and the inside edge of each hack shall be no further than 3 inches (7.62 centimetres) from the centre line.
 - (b) If one moveable hack is used, it shall be placed with the back edge of the hack on the hack line and be either centered on the centre line or with the inside edge no further than 3 inches (7.62 centimetres) from the centre line (left or right).
 - (c) If one fixed hack is used, it shall be placed with the back edge of the hack on the hack line and centered on the centre line.
- (7) The diagram herein shows the proper layout of the sheet in accordance with the measurements in this section.

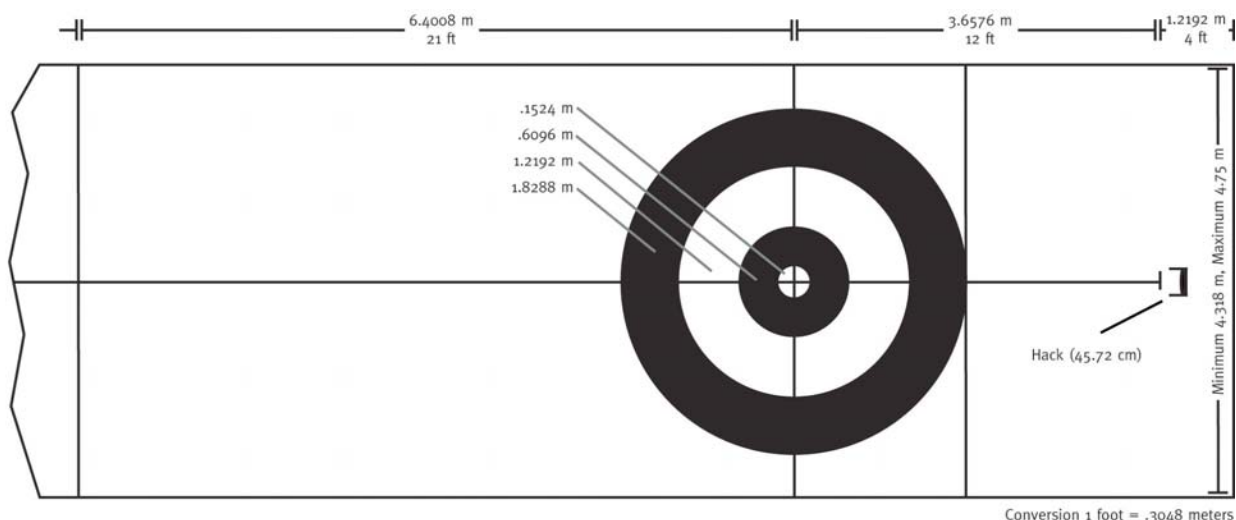

4. Stones

- (1) Curling stones shall be of circular shape.
- (2) Curling stones, including handle and bolt, shall weigh a maximum of 44 lbs. (19.96 kilograms), shall have a maximum circumference of 36 inches (91.44 centimetres) and shall be a maximum of 4.5 inches (11.43 centimetres) in height, measured between the bottom and top of the stone.
- (3) Two sets of eight stones shall be assigned for each sheet of play and only the assigned stones shall be used unless otherwise directed by an official.
- (4) A team member or coach shall not physically alter the running surface or weight of either team's assigned or selected game stones in any manner.

Penalty - Situation #1: If the violation occurred prior to the delivery of the stone, the official shall assign a replacement stone to the offending team. If a replacement stone is not available, the official shall allow the redelivery of a previously delivered stone or facilitate the dual delivery of a stone yet to be delivered.

Penalty - Situation #2: If an altered stone is delivered prior to an official intervening in the game, the official shall allow all stones to come to rest and provide the non-offending team with the option of:

- i) allowing the play to stand; or
- ii) having the official remove the delivered stone from play and replacing all affected stones as close as possible to their original positions.

Upon completion of the end, the official shall then apply the penalty for situation #1.

Interpretation: If a player or coach physically altered the running surface or weight of the opponent's stone(s), the matter shall be dealt with by the official under the Special Rules section of the Rule Book - "Obligations of Competitors and Coaches".

- (5) If a stone is broken in play, a replacement stone shall be placed by the official where the largest fragment comes to rest. The inside edge of the replacement stone shall be placed in the same position as the inside edge of the largest fragment with the assistance of a measuring stick.
- (6) A stone that rolls over in its course or comes to rest on its side or top shall be removed immediately from play.
- (7) All 16 stones originally on the sheet at the start of a game shall be delivered in every completed end. No interchange of stones or redelivery of previously delivered stones in that end may occur unless so directed by the official.

Penalty: If a violation of Rule 4(7) occurs, the official shall allow the delivered stone and all affected stones to come to rest and provide the non-offending team with the option of:

- i) allowing the play to stand; or
- ii) having the official remove the stone just delivered from play and replacing all affected stones as close as possible to their original positions.

- (8) Teams shall not place any sort of cover over the stones under any circumstances.

Penalty: The covers shall be removed by the official immediately and returned to the team at the conclusion of the competition.

5. Teams

- (1) Every team shall be composed of a minimum of four players as determined by the rules of the competition except as provided for in Rule 5(5). Prior to each game, a five member team shall designate the four eligible members of the team who will commence play as players for that game. If the fifth member is registered as a player he/she shall be recognized as the alternate for that game.
- (2) Unless otherwise specified in the rules of the competition:
 - (a) the teams opposing each other in a game shall toss a coin to determine which team plays the first stone of the first end. The winner of the toss has the choice between playing the first or second stone of the end, and
 - (b) the team that plays the first stone of the end has choice of handle colour.

In the second and subsequent ends, the winner of the preceding end shall play the first stone of the end except as provided for in Rule 8(1)(a) and 8(2)(d).

- (3) Each player on a four-player team shall deliver two stones in each end alternately with his/her opponent.
- (4) The delivery rotation declared by a team prior to the start of a game shall be followed throughout that game except as provided for in Rule 5(5), 5(6) or 5(7).
- (5)
 - (a) A team shall include a minimum of two players from the original team and an alternate or player(s) from the players' pool if the rules of the competition so provide.
 - (b) A team may play with three players if the rules of the competition so provide, with the first two players each delivering three stones in each end. Under no circumstance shall a team play with fewer than three players delivering stones.
 - (c) A team that is missing a player(s) and has a team alternate shall activate the team alternate.
 - (d) A team that is missing a player(s) and does not have a team alternate may access the players' pool if the rules of the competition so provide.
 - (e) An alternate player or player(s) from the players' pool who joins a team prior to the start of a game may deliver stones in any position of the delivery rotation of his/her team. The team shall declare their delivery rotation at this time.
 - (f) An alternate player or player(s) from the players' pool who joins a team between ends may deliver stones in any position of the delivery rotation of his/her team. Players may move up or down the delivery rotation only as

required to position the alternate player or player(s) from the players' pool and the team shall re-declare their delivery rotation at this time.

- (g) During an end in play, if a player(s) is unable to complete the delivery rotation declared by the team at the start of the game, the team may activate the team alternate or player(s) from the players' pool subject to:
- i) an alternate player or player(s) from the players' pool may only enter a game during an end if they deliver a stone within that end; and
 - ii) an alternate player or player(s) from the players' pool who enters a game during an end shall replace the sidelined player(s) in the team's delivery rotation for that end; and
 - iii) at the beginning of the next end, the alternate player or player(s) from the players' pool may deliver stones in any position of the delivery rotation of his/her team. Players may move up or down in the delivery rotation only as required to position the alternate player or player(s) from the players' pool and the team shall re-declare their delivery rotation at this time; and
 - iv) the replaced player shall not rejoin the team until the next game unless the team loses a subsequent player(s) and is therefore placed in a default position as per Rule 5(5) (a) and (b).
- (6) (a) A team that commences a game with three players and expects the fourth player to join the team during the game shall establish the team's four player delivery rotation prior to commencing the game.
- (b) A player who is late for a game may enter the game between ends or may enter an end already in progress providing he/she is able to deliver a stone within the team's established delivery rotation.
- (c) A player who has left a game may re-enter the game between ends or during an end already in progress providing he/she is able to deliver a stone within the team's established delivery rotation. If an alternate player or player from the players' pool has been activated, the replaced player shall not rejoin the team until the next game except as provided in Rule 5(5)(g) iv).
- (7) (a) If a player delivers his/her first stone of the end and is unable to deliver his/her second stone of the end and the rules of the competition allow the team to continue play with three players and the team chooses to play with three players, the following procedures shall be followed:
- If the lead player, the second player shall deliver the lead player's stone.
 - If the second player, the lead player shall deliver the second player's stone.
 - If the third player, the second player shall deliver the third player's stone.

- If the fourth player, the third player shall deliver the fourth player's stone.
- (b) If a player is unable to deliver both his/her stones during an end and the rules of the competition allow the team to continue with three players and the team chooses to play with three players, the following procedures shall be followed for the end in progress:
- If the lead player, the second player shall deliver both of the lead player's stones and one of the second player's stones, and the third player shall deliver one of the second player's stones and both of the third player's stones.
 - If the second player, the lead player shall deliver the first of the second player's stones, and the third player shall deliver the second of the second player's stones and both of the third player's stones.
 - If the third player, the second player shall deliver both of the third player's stones.
 - If the fourth player, the third player shall deliver both of the fourth player's stones.

Penalty: If a violation of Rule 5(3), 5(4), 5(5), 5(6), or 5(7) occurs, the official shall allow all stones to come to rest and provide the non-offending team with the option of:

- i) allowing the play to stand; or
- ii) having the official remove the stone just delivered from play and replacing all affected stones as close as possible to their original position.

6. Skips

- (1) The skip has the exclusive direction of the game for his/her team and shall deliver stones in each end except as provided for in Rule 5(7).
- (2) Subject to Rule 5(4), the skip may play any position in the delivery rotation of his/her team. Regardless of the position played in the delivery rotation, the player designated as skip shall remain in that capacity throughout the course of that game except as provided for in Rule 5(6).
- (3) When it is the skip's turn to deliver, he/she shall elect a teammate to act as skip. Subject to Rule 5(4), the vice-skip may play any position in the delivery rotation of his/her team. Regardless of the position played in the delivery rotation, the player designated as vice-skip shall remain in that capacity throughout the course of that game except as provided for in Rule 5(6). The vice-skip shall assume the responsibilities of the skip when the skip is not on the playing surface.

Penalty: If a violation of Rule 6(1), 6(2) or 6(3) occurs, the official shall allow all stones to come to rest and provide the non-offending team with the option of:

- i) allowing the play to stand; or
- ii) having the official remove the stone just delivered from play and replacing all affected stones as close as possible to their original position.

7. Position of Players

(1) Members of the non-delivering team:

- (a) The skip and vice-skip and only the skip and vice-skip may be positioned inside the hogline at the playing end and shall position themselves behind the back line when the delivering team is in the process of delivery. Both players shall be motionless with their brooms positioned in a manner not to interfere with or distract the attention of the player who is in the process of delivery as provided for in Rule 9(3).
- (b) One player may take a stationary position by the backboard at the delivering end and to the side of the sheet. The player shall remain silent and motionless when the delivering team player is in the process of delivery as provided for in Rule 9(3).
- (c) The players not taking the positions 7(1)(a) or 7(1)(b) shall position themselves between the hoglines and to the extreme sides of the sheet when the delivering team's time clock is running. The players positioned in this area shall remain in single file when the delivering team player is in the process of delivery as provided for in Rule 9(3).
- (d) The non-delivering team members shall not take any position or cause such motion that would obstruct, interfere with or distract any member of the delivering team.

Penalty: If a violation of Rule 7(1)(a), 7(1)(b), 7(1)(c) or 7(1)(d) occurs, the official shall allow all stones to come to rest and provide the non-offending team with the option of:

- i) allowing the play to stand; or
- ii) recommencing the delivery of the stone; or
- iii) replacing all affected stones as close as possible to their original position and redelivering the stone.

(2) Members of the delivering team:

- (a) The skip or vice-skip shall be positioned inside the hogline and on the ice surface of the playing end while their team is in the process of delivery. They shall have choice of position for the purpose of directing play.

Penalty: If a violation of Rule 7(2) occurs, the official shall allow all stones to come to rest and provide the non-offending team with the option of:

- i) allowing the play to stand; or

- ii) having the official remove the stone just delivered from play and replacing all affected stones as close as possible to their original position.

8. Game Time Operation

- (1) The game time allotted to each team to complete a 10 end game shall be 73 minutes. The game time allotted to each team to complete each extra end shall be 9 minutes.

- (a) A stone that has reached the nearer tee line before the game time expires shall be allowed to continue and shall be considered as having been played within the allotted game time.

Penalty: If the allotted game time of a team expires before the team's final stone of the game has reached the nearer tee line, the official shall call a time out and apply the penalty as follows:

- i) If the non-offending team is ahead based on the points on the scoreboard and the counting stones in the house, they shall be declared the winner of the game;
 - ii) If the non-offending team is not declared the winner as per i), they shall be provided the opportunity to use their remaining game time to continue play in an attempt to tie or win the game as outlined in 8(2); or
 - iii) If the non-offending team has no stones left to deliver, the end shall be considered over and the score for the end determined as per Rule 14. If the game results in a tie, an extra end(s) shall be played in accordance with Rule 14(11). The team that incurred the game time violation shall deliver the first stone of the extra end.
- (2) A team may continue play after their opponent's game clock has expired in an attempt to tie or win the game within their allotted game time. This shall take precedence over Rule 5(3) and 9(9)(a).
 - (a) The team whose time has expired shall be considered the non-delivering team from this point on and all rules shall be applied accordingly.
 - (b) The non-offending team shall be allotted an interval of a maximum of 20 seconds between their consecutive deliveries. Time management shall be under the direction of the head official who shall communicate as required with the game timing official. Their game time clock shall start at the expiration of the 20 second interval or when the stone reaches the nearer tee line, whichever first occurs. Their game time clock shall continue to run until all stones have come to rest in play or crossed the back line.
 - (c) If the non-offending team scores sufficient additional points to win the game within their allotted game time, they shall be declared the winner.

- (d) If the non-offending team scores sufficient additional points to tie the game within their allotted game time, an extra end(s) shall be played in accordance with Rule 14(11). The first team to incur a game time violation shall deliver the first stone of the extra end.
 - (e) If the non-offending team is unable to score sufficient additional points to tie or win the game within their allotted game time, they shall lose the game.
- (3) A mandatory break of a minimum of 5 minutes shall take place at the conclusion of the fifth end. The delivering team's game time clock shall be started at the conclusion of this break. If a countdown clock is not in use, the team's game time clock shall be started when their stone reaches the nearer tee line. All other allotted time for breaks between ends including extra ends shall be determined by the rules of the competition or as determined by the head official.
 - (4) Delay of a game in progress due to accident or illness shall be at the discretion of the official.
 - (5) Delay of a game in progress for any reason excluding accident or illness shall not exceed 3 minutes.

Penalty: At the discretion of the head official, if the delivery of a stone is delayed for three minutes, the official shall provide the team whose time clock is running with a 30 second warning. Failure to complete the delivery of the stone within the 30 seconds shall result in forfeiture of the stone. A team may not call a time-out in this 30 second period if such a warning has been given to the team by the official.
 - (6) An official may call a time-out at any time and shall call an official's time-out when requested or required to make a ruling, measurement, judgement, to communicate or administer penalties.
 - (7)
 - (a) If a player is allowed or required to redeliver a stone, the time required shall not be deducted from the allotted game time for that team except as provided for in 9(5).
 - (b) If an end is replayed, the time clocks shall be reset to the time recorded at the completion of the previous end.
 - (8)
 - (a) Each team may call two 60-second time-outs per game excluding any extra ends. Each team may call one 60-second time-out during each extra end. Time-outs shall not be carried forward to the extra end(s) or from one extra end to another. The calling of time-outs is subject to Rule 8(5).
 - (b) During an end, a time-out may only be called from the playing surface by a player of the team whose game time clock is running. Between ends the

team who shall deliver the first stone of the subsequent end may call a time-out to commence at the completion of the break between ends.

- (c) The coach and alternate player shall only communicate with their team during a time-out that they or their opponent have called and, with the approval of the official, during breaks between ends when neither team's game time clock is running. Coaches and alternate players may physically signal a request for a time-out to their team players on the ice.
- (d) For communication as permitted in 8(8)(c);
 - (i) the coach and alternate player of the team who called the time-out may access the playing area adjacent to or at the end of the sheet but shall not access the playing surface.
 - (ii) the team that did not call the time-out may communicate with their coach and alternate at either end of the sheet but the coach and alternate shall not access the playing surface.

Interpretation: Ice access may be provided to either team by the head official as per the off ice limitations of the facility.

- (9) Except as provided for in Rule 17(4), the game and the delivering team's game time clock shall start at the conclusion of a one-minute countdown. If such a countdown function is not in use, the delivery team's game time clock shall be started when the first stone of the end reaches the nearer tee line.
- (10) The delivering team's game time clock shall continue to run until:
 - (i) all stones have come to rest in play or have crossed the back line, and
 - (ii) the sweepers/brushers and player who has just delivered have moved to the side of the sheet, and
 - (iii) the delivering team has relinquished control of the house.

At this time the opposing team becomes the delivering team and their game time clock shall be started.

Interpretation: In the event of a throw through, the delivering team's game time clock shall continue to run until the stone has crossed the far back line.

- (11) At the conclusion of each end [Rule 14(7)] both game time clocks shall be stopped for a period of time as determined by the rules of the competition or the head official. The appropriate game time clock shall be started at the conclusion of the predetermined period of time or when the first stone of the end reaches the nearer tee line, whichever occurs first.

9. Delivery

- (1) Only right-handed deliveries shall be initiated from the hack located to the left of the centre line and only left-handed deliveries shall be initiated from the hack located to the right of the centre line. Both right-handed and left-handed deliveries may be initiated from a hack located on the centre line.

Interpretation: If a single, moveable hack is in use it shall be positioned as required by the delivering team in accordance with Rule 3(6) and 9(1).

Interpretation: The delivery and release of a curling stone are intended to occur within a reasonable proximity to the centre line. Any attempt to change the angle of the delivery/release to gain an unfair advantage shall be dealt with by the head official and may result in forfeiture of the delivered stone.

Penalty: If a violation of Rule 9(1) occurs the official shall allow all stones to come to rest and provide the non-offending team with the option of:

- i) allowing the play to stand; or
 - ii) having the official remove the stone just delivered from play and replacing all affected stones as close as possible to their original position.
- (2) A player may position him/herself in the hack in preparation for the delivery of a stone when either team's time clock is running or during a time-out.
- (3) (a) A player whose time clock is running is deemed to be in the process of delivery from the time the player is positioned in the hack until the stone is released.
- (b) A player shall only commence forward progression from the hack with a stone when his/her time clock is running except as provided for in Rule 8(2)(b), 8(7), 8(9) and 8(11).

Penalty: If a violation of Rule 9(3)(b) occurs, the official shall allow all stones to come to rest and provide the non-offending team with the option of:

- i) allowing the play to stand; or
 - ii) have the official replace all affected stones to their original positions and direct the redelivery of the stone with the delivering team's time clock running.
- (4) In the delivery of a stone, the stone shall be released before the stone has reached the nearer hogline.

Penalty Situation #1: If a violation of Rule 9(4) occurs when the hogline detection device is not being used, the delivered stone and all affected stones shall come to rest before any action is taken. The official shall remove the stone just delivered from play and replace all affected stones as close as possible to their original positions.

Penalty Situation #2: If a violation of Rule 9(4) occurs when the hogline detection device is being used, the red light displayed in the handle will come on and the delivering team sweepers/brushers shall take responsibility for stopping the delivered stone prior to it reaching the playing end and guiding it across the back line and out of play.

- (5) If a player wishes to recommence the delivery as a result of his/her team's action the player may do so providing the stone has not reached the nearer tee line. The stone shall be deemed to be "in the process of delivery" continuously from the first attempt to deliver until "delivered" and timed in accordance with Rule 8(10).

Interpretation: The delivery may be recommenced if the player's body or equipment reaches the tee line providing the stone does not.

- (6) If the official verifies that a player was distracted during the process of delivery [Rule 9(3)], as the result of an action not caused by any of the players on the sheet, the official shall allow all stones to come to rest and provide the delivering team with the option of:
- i) allowing the play to stand;
 - ii) recommencing the delivery of the stone; or
 - iii) replacing all affected stones as close as possible to their original positions and redelivering the stone.

- (7) If a player delivers a stone belonging to the opposing team, a stone belonging to his/her team shall be put in its place. If the teams cannot agree on its placement, the official shall place the stone.

- (8) (a) If a player delivers a stone out of proper rotation, the end shall continue and the delivery rotation shall continue to be in accordance with Rule 5(3) and 5(4), except as provided for in Rule 5(7).

Interpretation: This includes the situation when the team with last stone throws first.

- (b) If an error in delivery rotation causes a player on the same team to miss a turn, the player who has missed a turn shall deliver the last stone for his/her team in the end.

Interpretation: This rule applies to the situation when the second player delivers the lead player's second stone and other similar delivery rotation mistakes.

- (c) If a team or official realizes that the delivery of a stone has been missed but is unable to determine which player missed his/her turn, the lead of the team that missed a turn shall play the last stone for his/her team in that end.
- (9) (a) If a team delivers two stones in succession in the same end, the official shall remove the second stone that was played, replace any stone(s) displaced by the stone and the end shall continue. The delivery rotation of the offending team shall be altered for that end so that the player who delivered the second of the two stones delivered in succession shall deliver the last stone for his/her team in that end.

- (b) If the non-offending team delivers a stone prior to the error in delivery rotation being detected, the end shall be continued. If the non-offending team has last stone they shall deliver the last two stones of the end in succession. If the non-offending team is the team who started the end without last stone they shall deliver the last stone of the end.
- (10) If a player on a four player team delivers three stones in one end, except as provided for in Rule 5(7), the end shall be continued and the fourth player on the offending team shall deliver one stone only in that end.
- (11) If the handle came off a stone during the process of delivery [Rule 9(3)] the official shall provide the delivering team with the option of:
- i) allowing the play to stand, or
 - ii) redelivering the stone after all affected stones have been replaced as close as possible to their original position.

The delivering team must make their choice prior to the opposition delivering their next stone.

Interpretation: This does not apply to a handle that is loose but did not separate from the stone.

10. Touched Delivered Stone or Stone(s) Set in Motion

- (1) A delivered stone or stone set in motion shall not be touched by any player, equipment or personal belongings of the team to which it belongs.

Interpretation: If the violation occurs after the stone has been released, the player at fault shall declare the violation, allow the touched delivered stone or stone set in motion to come to rest and then summon an official.

Interpretation: A stone which has been released (fingers and thumb no longer in contact with the handle) and then retouched by the delivering player is considered a touched delivered stone and thus a breach of Rule 10 (1). A player who repositions his/her hand on the handle while in the process of delivery and does so without losing contact with the handle is not in breach of Rule 10 (1).

Penalty: The official shall remove the touched stone from play and replace all affected stones as close as possible to their original positions unless the non-offending team requests either of these alternative options:

- i) allowing the play to stand; or
- ii) placing the touched stone and all stones it would have affected where they would have come to rest had the violation not occurred. This option is only applicable where the violation occurred inside the hogline at the end of play or involved a stone considered to be in play.

- (2) A delivered stone shall not be touched by any player of the opposing team or their equipment nor shall they cause the stone to be touched.

Interpretation: The player at fault shall declare the violation, allow the touched delivered stone to come to rest and then summon an official.

Penalty: The official shall provide the non-offending team with the option of:

- i) allowing the play to stand;
- ii) replacing all affected stones as close as possible to their original position and redelivering the stone; or
- iii) placing the touched stone and all stones it affected or would have affected where they would have come to rest had the violation not occurred. This option is only applicable where the violation occurred inside the hogline at the end of play or involved a stone considered to be in play.

- (3) A stone set in motion shall not be touched by any player of the opposing team or their equipment nor shall they cause the stone to be touched.

Interpretation: The player at fault shall declare the violation, allow the touched stone set in motion to come to rest and then summon an official.

Penalty: The official shall provide the non-offending team with the option of:

- i) allowing the play to stand; or
- ii) placing the touched stone and all stones it affected or would have affected where they would have come to rest had the violation not occurred.

- (4) If a delivered stone or a stone in the process of delivery was touched or caused to be touched by an external force, i.e. stone, broom or brush from another sheet, spectator, etc., the player shall redeliver the stone. If the touched stone has displaced other stones, they shall be replaced as close as possible to their original positions by the official prior to redelivery

- (5) If a stone(s) set in motion was touched or caused to be touched by an external force, the official shall place the stone(s) set in motion and all stones they would have affected where they would have come to rest had the incident not occurred.

11. Displaced Stationary Stones

- (1) A stationary stone shall not be displaced by a player or that player's equipment nor shall a player cause a stone to be displaced by an opposing player or that player's equipment.

Penalty - Situation #1: If the displaced stone did not alter and would not have altered the course of a delivered stone or stone in motion:

- i) the non-offending team shall replace the displaced stone(s) as close as possible to its original position, and
- ii) If the teams cannot agree on the original position, the official shall replace the displaced stone(s) as close as possible to its original position, and

- iii) If the displacement occurred while playing the final stone of the end and/or prior to agreement of the score, Rule 14(9) shall apply.

Interpretation: If there is any question as to which stone(s) was closer to the tee, the displaced stone shall be positioned in favour of the non-offending team.

Penalty - Situation #2 If the displaced stone altered or would have altered the course of a delivered stone or stone set in motion, the official shall allow all stones to come to rest and remove the stone just delivered or stone set in motion from play and replace all affected stones as close as possible to their original position unless the non-offending team requests either of these alternative options:

- i) allowing the play to stand; or
- ii) placing the stone just delivered or stone set in motion and all stones it would have affected where they would have come to rest had the violation not occurred.

Interpretation: If there is any question as to which stone(s) would have been closer to the tee had the violation not occurred, the stone(s) that was affected or would have been affected by the delivered stone or stone set in motion shall be positioned in favour of the non-offending team.

- (2) The delivering team shall prevent a stationary stone(s) from being displaced by a stone(s) that is deflected from a divider or from a stationary stone on another sheet.

Penalty:

- i) The non-offending team shall replace the displaced stationary stone(s) as close as possible to its original position, and
- ii) If the teams cannot agree on the original position, the official shall replace the affected stone(s) as close as possible to its original position, and
- iii) If the displacement occurred while playing the final stone of an end and prior to agreement of the score, Rule 14(9) shall apply.

Interpretation: If there is any question as to which stone(s) was closer to the tee or would have been closer to the tee had the violation not occurred, the displaced stone(s) or stone(s) in motion shall be positioned in favour of the non-offending team.

- (3) If the stones are displaced during an end in a way other than stated in the preceding rules, the official shall determine, in consultation with the teams, the positions to which the stones are to be returned, subject to:
 - a) If the teams cannot agree on the original position and the official cannot determine the original positioning of the displaced stones relative to which was closer to the tee, the end shall be replayed; and
 - b) If the displacement occurred at the conclusion of play in an end and prior to agreement of the score, Rule 14(10) shall apply.

12. Sweeping/Brushing

- (1) Between the tee lines, all members of the delivering team may sweep/brush any of their team's stones that have been delivered or set in motion.
- (2) Only the skip or vice-skip of the non-delivering team may sweep/brush their team's stone(s) after it is set in motion.
- (3) Behind the tee line, only one player from each team may sweep/brush at one time. This may be the skip or vice-skip of either team or the lead or second of the delivering team.

Interpretation: The only time a lead or second of the delivering team may sweep/brush behind the tee line is when sweeping/brushing his/her team's delivered stone or any stone set in motion.

- (4) Behind the tee line, the delivering team shall have first privilege of sweeping/brushing any stone. If their choice is not to sweep/brush, they shall not obstruct or prevent the non-delivering skip or vice-skip from sweeping/brushing the stone.
- (5) An opponent's delivered stone or stone set in motion shall not be swept/brushed until it reaches the farther tee line and sweeping/brushing shall only take place behind the tee line.

Penalty: If a violation of Rule 12(1), 12(2), 12(3) 12(4) or 12(5) occurs, the official shall allow all stones to come to rest and provide the non-offending team with the option of:

- i) allowing the play to stand; or
 - ii) having the official place the stone and all stones it would have affected where they would have come to rest had the sweeping/brushing violation not occurred.
- (6)
 - (a) The sweeping/brushing motion shall be from side to side.
 - (b) The sweeping/brushing motion shall not leave any debris in front of a delivered stone or stone set in motion.
 - (c) The final sweeping/brushing motion shall finish to either side of the delivered stone or stone set in motion.
 - (7) All sweeping/brushing shall take place in front of the delivered stone or stone set in motion and within 6 feet (1.83 meters) of the stone.
 - (8) When sweeping with a corn/straw broom, the sweeping motion shall take place with the corn/straw pointing in the direction of play.

Interpretation: Backward sweeping with a corn/straw broom is not acceptable.

Penalty: If a violation of Rule 12(6), 12(7) or 12(8) occurs, the official shall allow all stones to come to rest and provide the non-offending team with the option of:

- i) allowing the play to stand;
- ii) having the official remove the unfairly swept/brushed stone from play and replace all affected stones as close as possible to their original position; or
- iii) placing the unfairly swept/brushed stone and stone(s) it would have affected where they would have come to rest had the sweeping/brushing violation not occurred.

13. Free Guard Zone

- (1) The free guard zone is the area between the hogline and the tee line, excluding the house.

Interpretation: A stone which comes to rest biting or in front of the hogline after making contact with a stone in the free guard zone is considered to be in the free guard zone. A stone which comes to rest outside the house but biting the tee line is not considered to be in the free guard zone.

- (2) Any stationary stone(s) belonging to the opposition that is located in the free guard zone shall not be moved to an out-of-play position by the delivering team prior to the delivery of the 5th stone of the end.

Penalty: A stone that is delivered prior to the 5th stone of the end that results in an opposition stone being moved from the free guard zone, either directly or indirectly, to an out-of-play position is an infraction which shall result in the delivered stone being removed from play and any other stone if moved being replaced as close as possible to its original position. If the opposing teams cannot agree on the stone(s) original position it shall be replaced by an official.

Interpretation: A delivered third or fourth stone of an end may hit an opposition stone(s) located in the free guard zone on to a stone(s) not in the free guard zone providing that any opposition stone originally located in the free guard zone remains in play. If this action results in an opposition free guard zone stone being moved to an out-of-play position, the penalty described above will apply. You may move your own stone from the free guard zone or remove your own stone from the free guard zone, providing you do not cause an opposition stone to be moved from the free guard zone to an out-of-play position.

- (3) After the delivery of each of the first three stones of an end it is the responsibility of the skip of the team who is about to deliver to ensure agreement with the opposing skip as to whether or not any of the stone(s) in play have come to rest in the free guard zone. If they cannot agree, an official shall make the determination by using the six foot measuring stick. If the position of another stone(s) hinders the use of the six foot measure the official shall reposition the stone(s), complete the measurement and replace the stone(s) to its original position.

14. Stones in Play and Scoring

- (1) A stone that does not come to rest inside the inner edge (house side) of the farther hogline shall be removed from play immediately except where it has struck another stone lying in play.

Interpretation: A stone which crosses the hogline but, when stopping, spins such that it comes to rest biting the hogline, is considered "out of play".

- (2) A stone coming to rest beyond the outer edge of the back line shall be immediately removed from play.

Interpretation: A stone which crosses the back line but, when stopping, spins such that it comes to rest biting the back line, is considered "in play".

- (3) A stone that touches a sideline, hits a divider or comes to rest biting a sideline shall be removed immediately from play.

Interpretation: If a delivered stone or stone in motion hits a stationary stone and a sideline or divider at the same time, the stationary stone shall be allowed to take its course as if it had been hit first.

- (4) A game shall be decided by a majority of points.

- (5) Each stone, any part of which is within 6 feet (1.83 meters) of the tee, is eligible to be counted.

- (6) A team scores one point for each eligible stone that is closer to the tee than any stone of the opposing team.

- (7) An end shall be decided when the skips or vice-skips in charge of the house at the time agree upon the score for the end.

- (8) If two or more stones are tied, then none of the tied stones shall count and only stones closer to the tee than the tied stones shall be eligible to be counted. If the tied stones are to determine which team shall count in that end, the end shall be considered blank.

- (9) If a stone(s) which may have affected the points scored in an end is displaced prior to the skips or vice-skips deciding the score, the team causing the displacement shall forfeit the point(s) involved.

- (10) Should an individual other than the two teams or their coaches displace or cause the displacement of a stone(s) prior to agreement of the score or a measure being determined, the following shall apply:

- (a) Preceding the final end:
i) If the displaced stone(s) would have determined who won an end, the end shall be replayed.

- ii) If a team secured a point(s), and the displaced stone(s) would have determined if an additional point(s) was scored, that team shall have the option of replaying the end or keeping the point(s) already secured and proceeding to the next end.
- (b) In the final end:
- i) If the game is tied and the displaced stone(s) would have determined which team won the game, the end shall be replayed.
 - ii) If the displaced stone(s) would have determined if the game was tied or lost by the team that was behind in points, that team shall have the option of replaying the end or keeping the point(s) they had already secured and playing an additional end without last rock.
 - iii) If the team that was behind in points had already secured sufficient points to tie the game, and the displaced stone(s) would have determined if they won the game, that team shall have the option of replaying the end or keeping the point(s) already secured and playing an additional end, with last rock being determined by a single draw to the tee with sweeping/brushing. The team who was ahead in points when the end began shall have the choice of drawing first or last.
 - iv) If the displaced stone(s) would have determined if the game was lost, tied or won, the team that was down in points shall have the option of replaying the end or keeping the point(s) already secured, if any, and playing an additional end, with last rock being determined by a single draw to the tee with sweeping/brushing. The team who was ahead in points when the end began shall have the choice of drawing first or last.

Interpretation: Rule 14(10)(b)(iv) applies to the following types of situations:

- A team is one down going home and measuring two of their stones to determine if they have lost, tied or won the game.
 - A team is two down going home counting one and measuring two of their stones to determine if they have lost, tied or won the game.
- (11) If after regulation play [Rule 17(1)], the score is tied, play shall be continued without changing the rotation of play (end to which the stones are thrown) for such additional end or ends as may be required to decide the winning team.

15. Measuring

- (1) All measurements shall be conducted by an official unless otherwise specified in the rules of the competition.
- (2) Measurements shall be taken from the tee to the closest part of the stone.

Interpretation: Because stones may vary in diameter, measurements shall not be taken from the tee to the farthest part of a stone.

Interpretation: The measure shall result in the stones being declared tied where there is not a discernible difference with the measuring device being used.

- (3) No physical device to aid visual observation shall be used in measuring prior to the last stone delivered in the end coming to rest except as provided for in Rule 13(3) and 15(5).
- (4) Decisions on whether a stone is in or out of play at the hogline, sidelines and back line shall be visual (no accepted measuring device) except as provided for in Rule 15(5). If the opposing skips cannot agree, the official shall make the final decision.
- (5) A skip may request that an official conduct a measurement when a stone is located on the back line in proximity to the centre line (6:00 position) to confirm if the stone is in or out of play. The 6 foot (1.83 metres) measuring stick shall be used.

Interpretation: If the position of a stone(s) in the house makes it impossible to use the measuring stick to determine if a stone is in or out of play, the official shall make a visual determination and his/her decision shall be final.

- (6) If two or more stones are so close to the tee that a measuring device cannot be used, and if a visual comparison by an official cannot determine which stone is closest to the tee, the stones shall be considered tied. If these stones were to determine who counted in the end, the end shall be considered blank.
- (7) A measuring stick that measures a distance of six feet (1.83 metres) from the tee shall be used, if necessary, to confirm whether a stone is within six feet (1.83 metres) of the tee as provided for in Rule 13(3), 14(5) and 15(5).

16. Equipment

- (1) Any team equipment which may possibly come into contact with the playing surface is subject to inspection by an official prior to or during competition. The team equipment which is subject to inspection includes, but is not limited to, corn/straw brooms, brushes, sliders, grippers, shoes in general, sliding/delivery devices and on ice clothing. If the official determines the equipment is in conflict with the ideals of fair play, potentially damaging to the ice surface or not in compliance with the integrity and positive image of the championship, the official shall identify the equipment as being unacceptable and direct the team to remove the equipment from the playing surface.
- (2) Prior to the start of the competition:

- (a) all brushes, brush heads and synthetic corn/straw style brooms used for sweeping/brushing shall be inspected, tested and identified as acceptable for game play.
 - (b) all sliding/delivery devices shall be inspected, tested and identified as acceptable for game play.
- (3) Prior to the start of each game, all corn/straw brooms to be used for sweeping shall be presented by the team to the official to be inspected, tested and identified as acceptable for game play.
- (4) At the start of each game, each player shall declare what type of sweeping/brushing device previously identified as acceptable that he/she shall be using for the duration of the game (brush, synthetic straw style broom or corn/straw broom). Players may change or exchange brushes, brush heads and synthetic straw style brooms during a game providing they have been identified as acceptable for game play. Players shall use the same corn/straw broom for the duration of the game and shall not exchange a corn/straw broom with another player.
- (5) A broom or brush broken during the game shall be replaced by the same type of sweeping/brushing device. The replacement shall be inspected and accepted for game play by an official prior to use if not previously inspected as per 16(2), 16(3) and 16(4).

Penalty: When any sweeping/brushing device is used that has not been identified as acceptable for game play, the official shall allow all stones to come to rest and provide the non-offending team with the option of:

- i) allowing the play to stand; or
- ii) having the official remove the swept/brushed stone(s) just delivered or set in motion from play and replace all affected stones as close as possible to their original position. The official shall ensure that the sweeping/brushing device is replaced with one marked acceptable for game play. The official may direct that the ice surface be cleaned.

Interpretation: The penalty shall only be applied prior to the delivery of the next stone.

- (6) The use of a curling aid commonly referred to as a “delivery balance device” is considered acceptable. The balance device shall not exceed 5 feet (152.4 centimetres) in length and 12 inches (30.5 centimetres) in width. Height may vary.
- (7) Teams shall not use any electronic communication device or any modification to the voice, i.e. bull horn, whistle, etc.

Penalty: The device shall be removed by the player and given to the official and it shall be returned to the team at the conclusion of the competition.

- (8) The use of a curling aid commonly referred to as a “delivery stick” which enables the player to deliver a stone without placing a hand on the handle is not considered acceptable at the Canadian Seniors, Juniors, Mixed, Men’s, and Women’s Championships.

17. Game Duration and Postponement

- (1) A game shall be of such length or duration as is stated in the rules governing the competition.
- (2) The official may delay a game for up to one hour, after which time the game may be postponed. At the discretion of the official, when a game is delayed, it shall start at the point at which it was delayed or at the last end completed.
- (3) If for any reason a game is postponed to another time, the game shall continue from the last completed end.
- (4) The teams shall start the game at the time designated by the competition draw.

Penalty: If a team does not commence play at the designated time:

- i) The offending team's game time clock may be started, at the discretion of the official;
- ii) For each full five minutes that the offending team does not commence play, the non-offending team shall be granted one point and one end shall be considered to have been played;
- iii) When the game does start, the offending team shall commence the game with the remaining time left on their game time clock. The non-offending team's game time clock shall be reduced by the same amount as that of the offending team or by five minutes for each end considered to have been played whichever is less. No reduction to the non-offending team’s time clock shall be made before one end is considered to have been played;
- iv) If the non-offending team has been granted a point(s), the offending team shall lead in the first end to be played. Play shall commence from the end of play that reflects the number of ends that are considered to have been played. Handle colour shall remain as determined by the competition draw; and
- v) At the discretion of the official, after 30 minutes has elapsed the non-offending team shall be awarded the victory by a score of 10-0.

18. Head Official

- (1) The head official has the general supervision of and shall govern any competition to which he/she is assigned.
- (2) The rules pertaining to on-ice violations cannot be appealed beyond the head official.

- (3) Where so authorized, the head official may directly intervene at any time in any game and give such directions concerning conduct of the game and adherence to the rules as he/she considers proper.
- (4) The head official shall hear and determine appeals of decisions made by on-ice officials and supervisors. His/her decision is final.
- (5) The head official is authorized to make decisions on matters not covered by the rules and shall do so in accordance with equity.
- (6) The head official may recommend expulsion or suspension of any player or coach to the official curling body having jurisdiction. The expulsion or suspension may involve the competition at hand or future competitions governed by the curling body having jurisdiction.
- (7) The head official may expel a player or coach from the game or competition area for what he/she considers to be abusive or unacceptable behaviour including refusal to comply with the rules and direction provided by an official.

19. Miscellaneous

- (1) If any exceptions to the preceding rules are necessary to accommodate a player(s) with a physical disability, with the approval of the official, appropriate adjustments are considered acceptable.

Interpretation: Any adjustment made by an official shall not include the introduction of new or non-approved equipment into the game.

- (2) Smoking or drinking alcoholic beverages by a player or coach on or in proximity to the ice surface is prohibited.

Penalty: The official may suspend the player or coach from the game in which the violation took place.

- (3) If a competition has a specific dress code, the team members shall adhere to it.

Penalty: The head official may suspend the player from the game until the dress code has been met.